

Series 75

Steel Roller Shutters



Series 75 Roller Shutters consist of individual interlocking steel slats, providing high strength security for commercial and industrial applications such as factories, loading docks, workshops and warehouses.

FEATURES

- Interlocking steel slats
- Optional vision/ventilation

DOOR DIMENSIONS

- Maximum Door Height: 6500mm
- Maximum Door Width: 10000mm

NOTE: Maximum door dimensions may vary depending on wind loading and the door's design features and application. Maximum size may be reduced if the door is slotted or perforated (see Ventilation). In special applications, Series 75 Roller Shutters may be designed to suit larger sizes, consult manufacturer for further information.

RECOMMENDED SPECIFICATIONS

Series 75 steel Roller Shutter with 75mm high slats in 0.6mm, 0.8mm, 1.0mm or 1.2mm thick material as manufactured by Airport Doors. The Roller Shutter operates by means of a flexible curtain made of interlocking steel slats winding onto an overhead drum and guided in steel door guides.

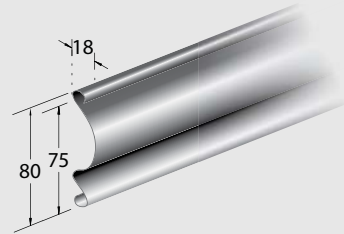

© Copyright 2015 Czapp Pty Ltd trading as Airport Doors. In line with Airport Doors' research and development program, Airport Doors reserves the right to change specifications at any time without notice.

Series 75

Steel Roller Shutters

CURTAIN

The Series 75 curtain is manufactured from individual, roll-formed, interlocking steel slats with a 75mm profile. The interlocking slats are roll-formed from galvanised steel sections of 0.6mm, 0.8mm or 1.0 mm thickness as standard, or 1.2mm thick for special applications. The thickness of steel is determined by the application and is dependent on the door width and wind loading. Alternating slats are fitted with nylon end clips to stop lateral movement of the curtain and to ensure smooth operation. When specified, deflection of the curtain can be reduced by installing the door higher than normal.

WIND LOCKS

When specified, wind lock clips are fitted to the ends of the slats to provide extra protection against excessive winds. As a guide wind locks are recommended for shutters over 6000mm wide; however in certain locations and applications e.g. high wind or cyclonic areas, wind locks may be required for shutters less than 6000mm wide. Refer to wind-loading chart (available from manufacturer) for further information. Wind lock clips are fabricated from cast iron to suit specially designed wind lock door guides and are fixed to every second or fourth slat as required for the application.

FINISH

The curtain is roll-formed from galvanised material as standard and can be powder coated (up to 9000mm wide) when specified. The drum and drum support brackets are prime-coated.

VENTILATION (OPTIONAL)

The Roller Shutter slats can be slotted or perforated to provide ventilation. The terms 'fully-slotted' or 'fully-perforated' refers to shutters in which all slats within the opening are slotted or perforated. 'Part-slotted' or 'part-perforated' refers to shutters that have a combination of slotted/perforated and non-slotted/perforated slats. Note, slotted or perforated shutters should be specified in powder coat finish (galvanised is not recommended).

Slotted Slats – Slots are 103mm wide by 19mm high at approximately 150mm intervals. When fully slotted, airflow of approximately 10% is achieved. Slotted shutters may reduce door strength and therefore may decrease the maximum door size available. Fully-slotted shutters should not exceed 3500mm high by 8000mm wide.

Perforated Slats – Perforated slats of 1.0mm thickness consist

of 2.0mm nom. diameter perforations at staggered pitch. Fully-perforated shutters provide approximately 20% airflow. Fully-perforated Series 75 Roller Shutters should not exceed 3500mm high by 6000mm wide. Size restrictions may also apply to part-perforated Roller Shutters.

PERSONAL ACCESS (PA) DOORS (OPTIONAL)

Where there is no other entrance into the building, PA Doors can be built into the Roller Shutter. Restrictions apply. PA Entry and Exit Doors are available for small to medium width Roller Shutters over 3000mm in height and that are not exposed to high wind loads. PA Entry and Exit Doors are fitted with a standard Lockwood 201 night latch. Other locks can be fitted if specified

Standard PA Entry Doors open inward and are 1000mm high by 600mm wide and are fitted approximately 210mm above floor level.

Standard PA Exit Doors open outward and are approximately 2040mm high by 1000mm wide and are fitted approximately 50mm above floor level.

NOTE: PA Entry and Exit Doors do not roll up with the shutter, and thus must be manually opened before operating the door. If the shutter has a PA Entry or Exit door and is motorised, a cut-out switch must be fitted to prevent accidental damage to the door. PA Entry and Exit Doors do not comply as fire exits.

BOTTOM RAIL

The bottom rail is manufactured from specially extruded, heavy duty, aluminium section, which interlocks with the bottom slat. Roller Shutters over 6500mm in width use a steel box section bottom rail. The bottom rail reinforces the Roller Shutter curtain and is fitted with a PVC bottom weather seal.

DOOR GUIDES

The door guides are manufactured from 2.5mm thick roll-formed galvanised steel with a depth of 78mm. Door guides are fixed to the walls using steel fixing lugs or can be welded directly to steel work. See installation drawing for further details.

WIND LOCK DOOR GUIDES

Wind lock door guides (where wind locks are specified) are manufactured from 3.0mm thick roll-formed galvanised steel with a depth of 100mm. See installation drawing for further details.



Series 75

Steel Roller Shutters

DRUM & SPRING ASSEMBLY

The drum consists of a seamless or spiral welded, cylindrical tube revolving around a central steel axle and encasing helical torsion springs matched to suit door size and weight. The springs are rolled from high grade spring wire and tempered. The drum is designed to provide minimal deflection over the door width.

DRUM SUPPORT BRACKETS

Series 75 Roller Shutter drum support brackets are manufactured from mild steel plate with a minimum thickness of 8mm.

FIXING REQUIREMENTS

The building construction (typically steel or concrete) must be structurally sound and have adequate strength to support the Roller Shutter and its fixing requirements. Consult manufacturer for further details.

LOCKING

Hand-operated Series 75 Roller Shutters are fitted with two shoot-bolts, fitted internally or externally to each end of the bottom rail.

Chain operated steel Roller Shutters are fitted with a steel chain lock designed to accommodate a padlock. As an optional extra, chain operated shutters can also be fitted with two shoot-bolts, fitted internally to each end of the bottom rail. (Padlocks not included).

Electric operated (motorised) doors are secured by the motor and its controls.

NOTE: If optional shoot-bolts are fitted to a motorised shutter, a cut out switch for each shoot-bolt must be fitted.

MULLIONS (OPTIONAL)

Centre door mullions can be used for wide openings to create multiple door installations. Centre door mullions of either a sliding or fixed type (as specified), are manufactured from mild steel plate with a standard width of 300mm. A sliding mullion is manually operated by disengaging top and bottom latches and sliding to one side of the doorway on an overhead sliding track fixed to the underside of the lintel. A fixed type mullion is not removable and is fixed to the floor and lintel.

OPERATION

Roller Shutters operate by means of a flexible interlocking steel

curtain, winding onto an overhead drum and guided in steel door guides. They are installed to the inside face of an opening and overlap the nibs and lintel ('behind-fix'). Series 75 Roller Shutters are available in hand operation, chain operation or electric operation.

HAND OPERATION

Series 75 Roller Shutters can be hand-operated up to 2200mm height and 2400mm width. As doors can become quite heavy, hand operation is not recommended over this size.

CHAIN OPERATION

Gearing is fitted to one end of the Roller Shutter and matched to suit the door size and weight. The curtain is opened and closed by hand chain via a reduction gear mechanism. **NOTE:** Chain operation is not recommended for Series 75 Roller Shutters over 20m².

MOTORISATION (ELECTRIC OPERATION)

Motorisation is via a geared electric motor and incorporates a standard reversing starter push-button station (control box) and an emergency hand chain operation in case of a power outage. The standard push-button station offers 'Up', 'Down' and 'Stop' functions.

Operator selection is dependent on the door size, door weight, wind loading, availability of power and the door's application. Motorisation is available in three-phase (415v) as standard, or single-phase (240v) power.

The provision of adequate mains power supply and isolator or GPO (as required) to motor location is the responsibility of the client. Wiring from the isolator and commissioning of the door, motor controllers and any ancillary hardware is by client, unless otherwise stated in writing.

Optional extras, such as high cycle motorisation, battery back-up and access control accessories are available upon specification.

For further information see Door Operators & Accessories.

OPTIONS

- Tapered bottom



Series 75

Technical Specs: Steel Roller Shutters

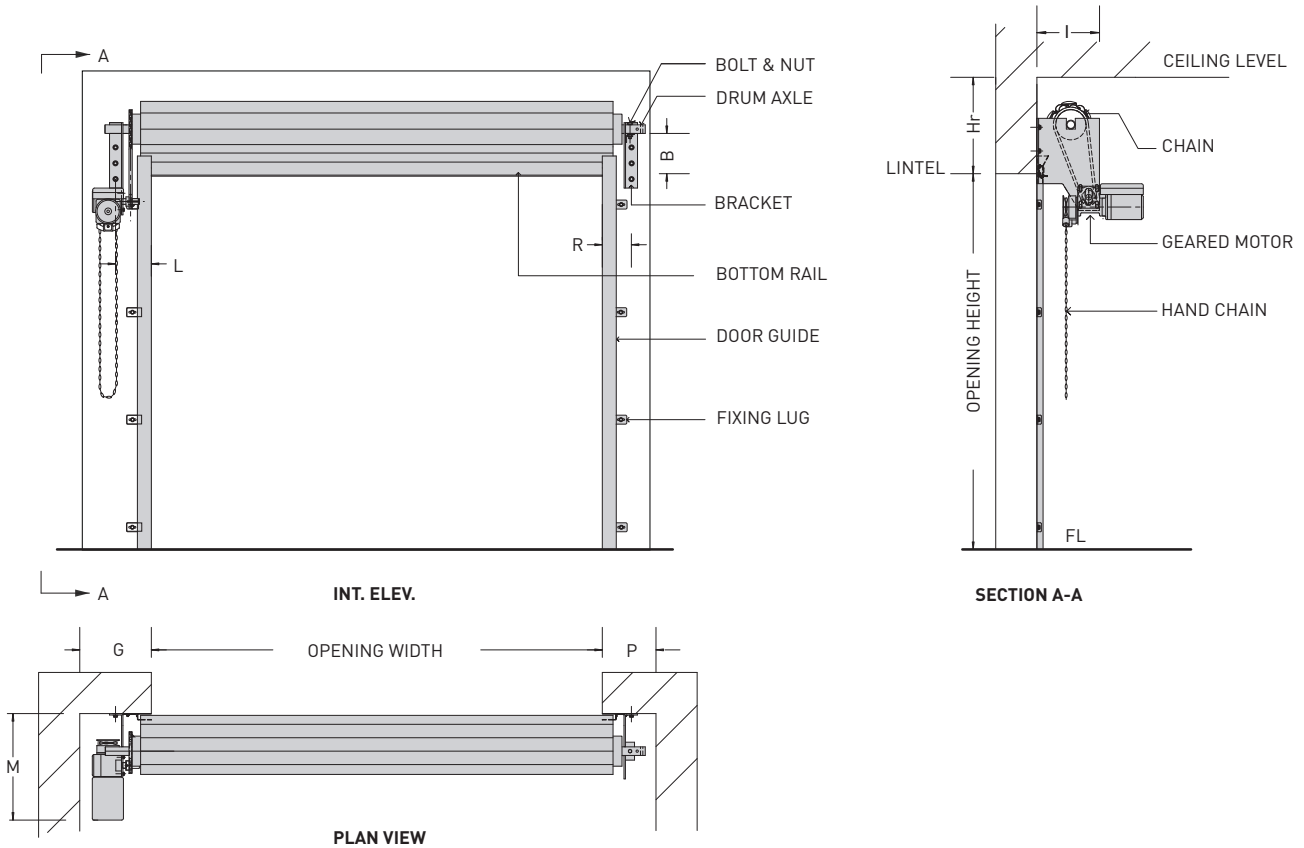

CLEARANCE DETAILS													
HEIGHT UP TO	WIDTH UP TO 8m				WIDTH UP TO 10m				OPERATION	DRIVEN END		PLAIN END	
	Hr	B	I	M	Hr	B	I	M		G	L**	P	R**
2400	530	325	410	595	550	335	410	595	HAND OPERATION	P	R	250	170
4300	600	385	430	595	610	390	430	595	CHAIN OPERATION	300	190	250	170
6500	690	450	550	675	800	375	680	675	MOTORISATION (STD)	500	190	250	170
									MOTORISATION (INBOARD*)	250	180	250	170

Notes:

- For hand operated doors, sideroom on one side only (P) can (where required) be reduced to 120 min.
- Standard chain operated or motorised doors have the drive unit fitted outboard.
- *Inboard motorisation is available when sufficient clearance is not available for standard motorisation. If fitted inboard, the drive unit fits partly within opening under drum/curtain. Add 150 to dimension M for inboard motorised doors.
- Door-stops on door guides are fitted on hand-operated or chain-operated shutters.
- **Where shutter has windlocks allow extra 10mm for 'R' and extra 40mm for 'L'.

Door Guides

Technical Specs: Steel Roller Shutters

SERIES 75, 100, & 130 STANDARD DOOR GUIDE

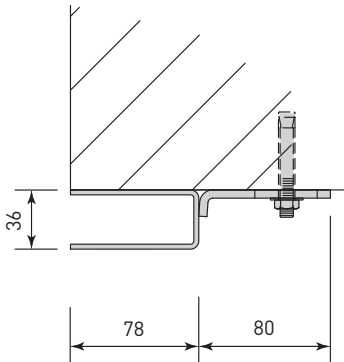

WINDLOCK DOOR GUIDES

SERIES 75

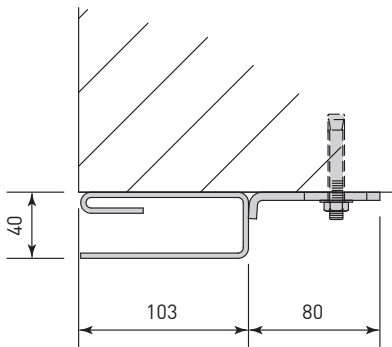

SERIES 100/130

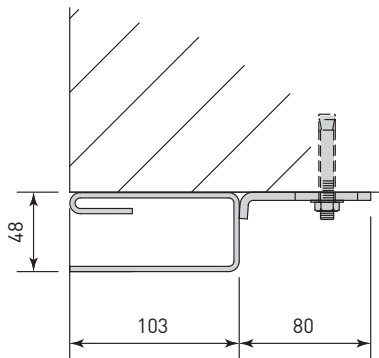

DETAIL : WINDLOCK

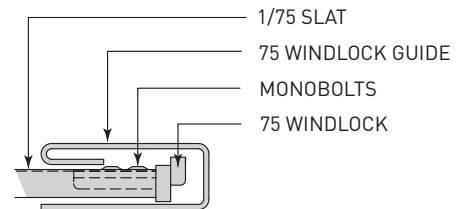

2 & 4 HOUR FIRE SHUTTER STANDARD DOOR GUIDE

